



LIPPERT COMPONENTS

**HYDRO-SYNC SLIDEOUT SYSTEM
OPERATION AND SERVICE MANUAL**

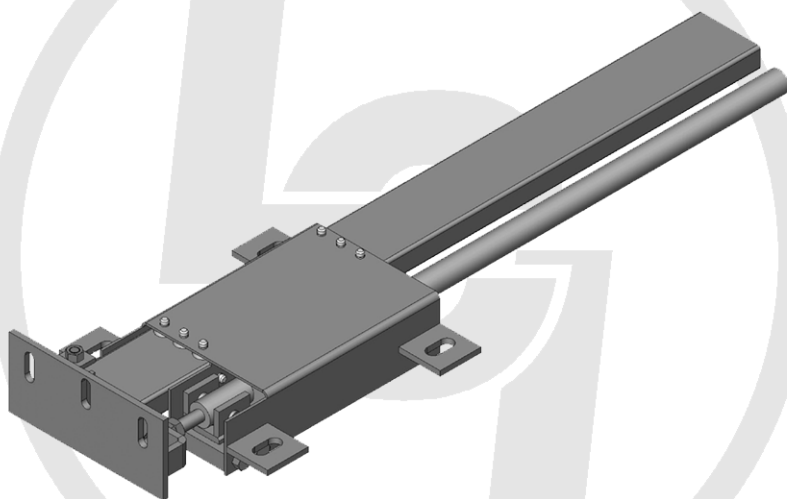



TABLE OF CONTENTS

SYSTEM.....	3
Warning.....	3
Description.....	3
Prior to Operation.....	4
	4
OPERATION.....	
Main Components.....	5
Mechanical.....	5
Electrical.....	5
Operating System.....	5
Extending Slideout Room.....	6
Retracting Slideout Room.....	9
Manual Operation.....	9
Preventative Maintenance.....	10
SERVICE.....	12
Fluid Fill Procedure.....	12
Troubleshooting.....	13
Chart.....	14
Power Unit.....	15
Bad Cylinder.....	16
Wiring Diagram.....	17
Ordering Parts.....	18

SYSTEM

WARNING

FAILURE TO ACT IN ACCORDANCE WITH THE FOLLOWING MAY RESULT IN SERIOUS PERSONAL INJURY OR DEATH.

The *Lippert Hydro-Sync Slideout System* is intended for the sole purpose of extending and retracting the slideout room. Its function should not be used for any other purpose or reason than to actuate the slideout room. To use the system for any reason other than what it is designed for may result in damage to the coach and/or cause serious injury or even death.

Before actuating the system, please keep these things in mind:

- 1. Parking locations should be clear of obstructions that may cause damage when the slideout room is actuated.**
- 2. Be sure all persons are clear of the coach prior to the slideout room actuation.**
- 3. Keep hands and other body parts away from slideout mechanisms during actuation. Severe injury or death may result.**
- 4. To optimize slideout actuation, park coach on solid and level ground.**

DESCRIPTION

The *Lippert Hydro-Sync Slideout System* is a hydraulic cylinder drive system. Utilizing a bidirectional electric motor to actuate the pump, moving fluid from the reservoir into the hydraulic cylinders to extend the room and pumping fluid back to the reservoir to retract the slideout. The *Lippert Hydro-Sync Slideout System* is designed as a negative ground system.

There are no serviceable parts within the power unit. If the motor, manifold, pump or reservoir fails, the entire power unit must be replaced.

Disassembly of the motor voids the warranty.

Mechanical portions of the slideout system are replaceable. Contact Lippert Components, Inc. to obtain replacement parts.

PRIOR TO OPERATION

Prior to operating the *Lippert Hydro-Sync Slideout System*, follow these four (4) guidelines:

1. Coach should be parked on the most level surface available.
2. The **PARKING BRAKE** must be engaged.
3. The coach's transmission must be in **NEUTRAL** or **PARK**.
4. The coach's ignition must be in the **RUN** position or the coach's engine must be running.

OPERATION

MAIN COMPONENTS

MECHANICAL

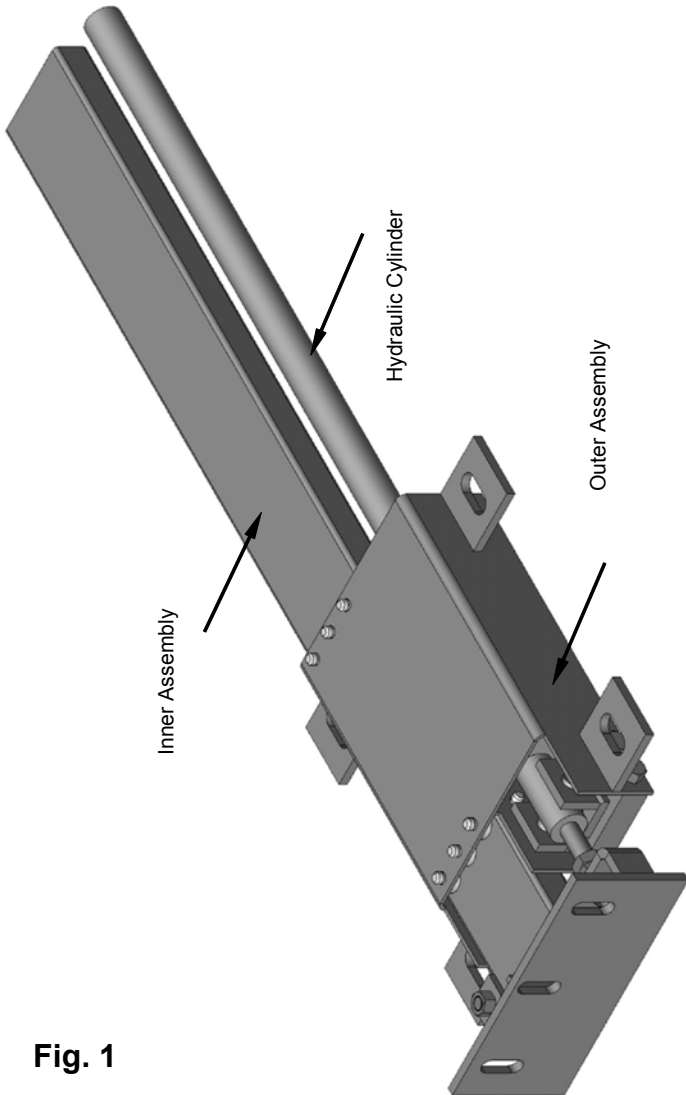
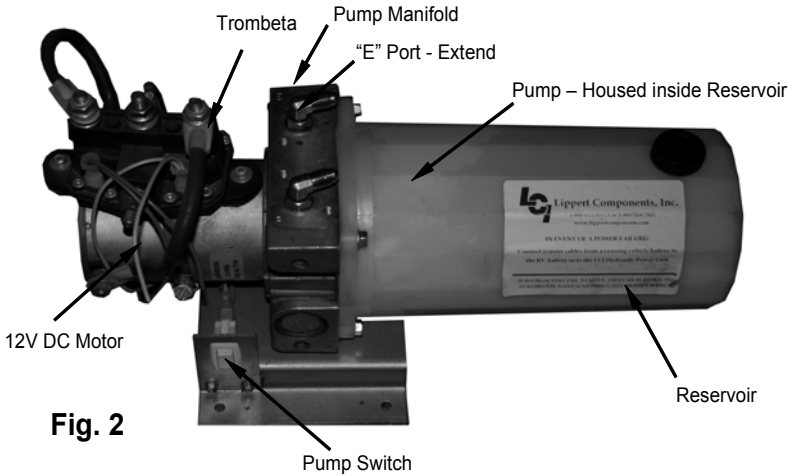

Fig. 1

ELECTRICAL

POWER UNIT – 12V DC MOTOR W/PUMP & RESERVOIR



WALL SWITCH

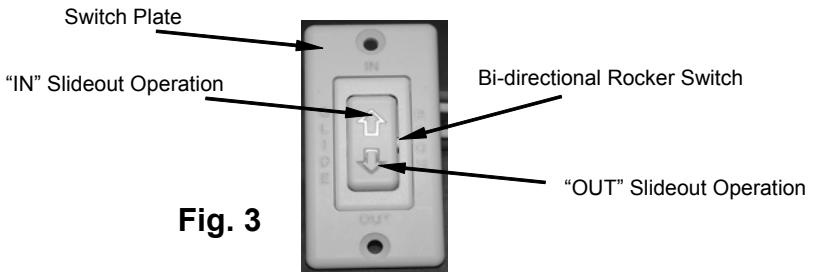

RELAY - TROMBETTA

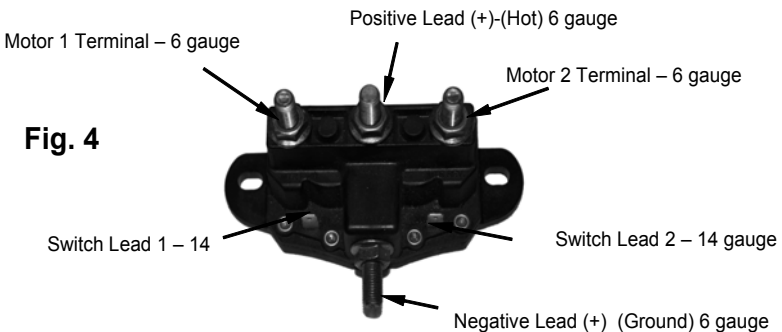

OPERATING SYSTEM

WARNING

FAILURE TO ACT IN ACCORDANCE WITH THE FOLLOWING MAY RESULT IN SERIOUS PERSONAL INJURY OR DEATH.

ALWAYS MAKE SURE THAT THE SLIDEOUT ROOM PATH IS CLEAR OF PEOPLE AND OBJECTS BEFORE AND DURING OPERATION OF THE SLIDEOUT ROOM.

ALWAYS KEEP AWAY FROM THE SLIDE RAILS WHEN THE ROOM IS BEING OPERATED. THE GEAR ASSEMBLY MAY PINCH OR CATCH ON LOOSE CLOTHING CAUSING PERSONAL INJURY.

INSTALL TRANSIT BARS (IF SO EQUIPPED) ON THE SLIDEOUT ROOM DURING STORAGE AND TRANSPORTATION.

EXTENDING SLIDEOUT ROOM

1. Level the unit.
2. Verify the battery is fully charged and hooked-up to the electrical system.
3. Remove the transit bars (if so equipped).
4. Press and hold the IN/OUT switch (Fig. 5B) in the OUT position until the room is fully extended and stops moving.
5. Release the switch, which will lock the room into position.
NOTE: If the slideout switch is held after the room is fully extended, the control will sense that the room has stopped and will shut off the motor after a few seconds.

RETRACTING SLIDEOUT ROOM

1. Verify the battery is fully charged and hooked-up to the electrical system.
2. Press and hold the IN/OUT switch (Fig. 5C) in the IN position until the room is fully retracted and stops moving.
3. Release the switch, which will lock the room into position.
NOTE: If the slideout switch is held after the room is fully retracted, the control will sense that the room has stopped and will shut off the motor after a few seconds.
4. Install the transit bars (if so equipped).

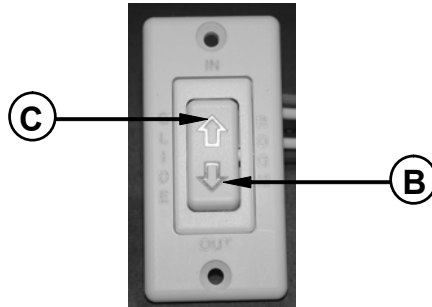

Fig. 5

MANUAL OPERATION

The *Lippert Hydro-Sync Slideout System* can be run with auxiliary power devices like electric drills, ratchet wrenches or cordless screwdrivers. In the event of electrical or system failure, this manual method of extending and retracting the slideout room can be used. A standard handheld drill is all that is required. A standard 38" room will take approximately 45 seconds to retract. See the instructions below.

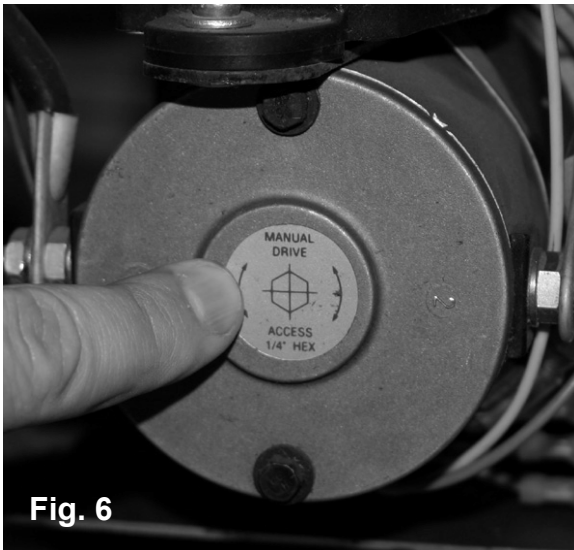

Fig. 6

1. Remove protective label. (See Fig 6).
2. Using a standard hex bit, insert into auxiliary drive device, i.e. cordless drill or screwdriver or ratchet wrench.

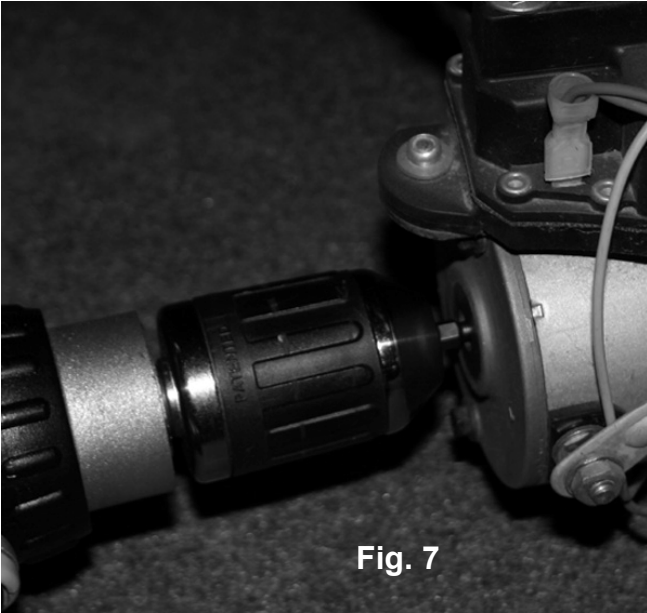

Fig. 7

3. Insert hex bit into coupler found under protective label. (See Fig. 7)
4. Run drill forward or clockwise to extend slideout room and in reverse or counterclockwise to retract slideout room.

PREVENTATIVE MAINTENANCE

The *Lippert Hydro-Sync Slideout System* has been designed to require very little maintenance. To ensure the long life of your slideout system, read and follow these few simple procedures.

WARNING

**DO NOT WORK ON YOUR SLIDEOUT SYSTEM UNLESS
THE BATTERY IS DISCONNECTED.**

**FAILURE TO ACT IN ACCORDANCE WITH THE FOLLOWING MAY
RESULT IN SERIOUS PERSONAL INJURY OR DEATH.**

The *Lippert Hydro-Sync Slideout System* has been static tested to over 6,000 continuous cycles without any noticeable wear to rotating or sliding parts. It is recommended that when operating in harsh environments and conditions (road salt, ice buildup, etc.) the moving parts be kept clean and can be washed with mild soap and water. No grease or lubrication is necessary and in some situations may be detrimental to the environment and long-term dependability of the system.

MECHANICAL

Although the system is designed to be almost maintenance-free, actuate the room once or twice a week to keep the seals and internal moving parts lubricated.

Check for any visible signs of “leaking” before and after movement of the system and the coach.

When the room is out, visually inspect the Inner and Outer Assemblies. Refer to Fig. 1 for location of inner assemblies. Check for excess buildup of dirt or other foreign material; remove any debris that may be present.

If the system squeaks or makes any noises it is permissible to apply a coat of lightweight oil to the drive shaft and roller areas but remove any excess oil so dirt and debris do not buildup. **DO NOT USE GREASE.**

ELECTRICAL

For optimum performance, the slideout system requires full battery current and voltage. The battery must be maintained at full capacity. Other than good battery maintenance, check the terminals and other connections at the battery, the control switch and the pump motor for corrosion and loose or damaged terminals. Check motor leads under the coach chassis. Since these connections are subject to damage from road debris, be sure they are in good condition.

Note: The *Lippert Hydro-Sync Slideout System* is designed to operate as a negative ground system. A negative ground system utilizes the chassis frame as the ground source. An independent ground wire back to the battery is not needed. It is important the electrical components have good wire to chassis contact. To ensure the best possible ground, a star washer should be used. Over 90% of unit electrical problems can be attributed to bad ground connections.

Note: For long-term storage: It is recommended that the room be closed (retracted) and if your unit is equipped with the IRC room control, it is recommended all of the control knobs be kept in the closed position.

**IF YOU HAVE ANY PROBLEMS OR QUESTIONS CONSULT YOUR
LOCAL AUTHORIZED DEALER OR CALL LIPPERT AT:
(866) 524-7821.**

SERVICE

FLUID FILLING PROCEDURE

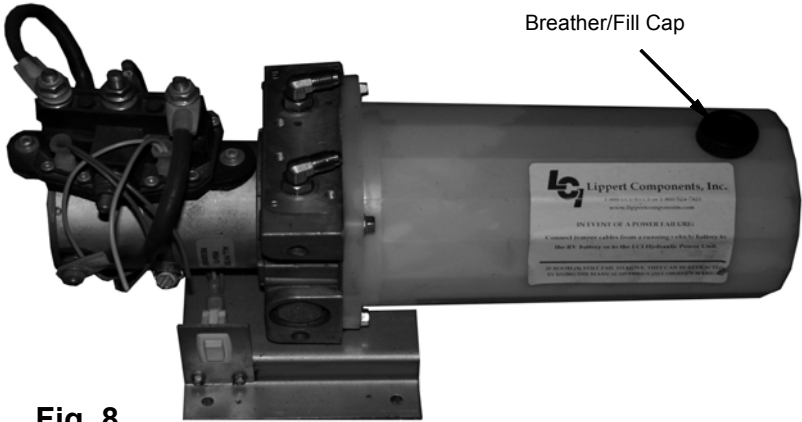

Fig. 8

The *Lippert Hydro-Sync Slideout System* uses automatic transmission fluid (ATF). Any ATF can be used. A full synthetic or synthetic blend works best such as Dexron III or Mercon 5. For best operation, fill system within ½” of the top when all slideouts are completely retracted. The see through reservoir makes it easy to check oil level. It is recommended that the oil level be checked prior to operating the system. Make sure the breather cap is free of contamination before removing, replacing or installing.

FILLING DIRECTIONS

Remove Breather/Fill Cap

Pour ATF into Breather/Fill opening.

Note: Do not allow any contamination into reservoir during fill process.

Note: Standard reservoir holds approximately 2 quarts (1.89 liters) of ATF.

Fill to within ½” of top.

Replace Breather/Fill cap when finished.

Note: System is self-purging. By simply cycling the system 2-3 times, any air in the system will be forced back to the reservoir and out of the Breather/Fill cap.

TROUBLESHOOTING

The *Lippert Hydro-Sync Slideout System* is only one of four interrelated slideout room system components. These four components are as follows: chassis, slideout room, coach and *Lippert Hydro-Sync Slideout System*. Each one needs to function correctly with the others or misalignment problems will occur.

Every coach has it's own personality and what may work to fix one coach may not work on another even if the symptoms appear to be the same.

When something restricts room travel, system performances will be unpredictable. It is very important that slide rails, inner and outer, be free of contamination and allowed to travel freely the full distance or "STROKE." Ice or mud buildup during travel is an example of some types of contamination that may occur.

When beginning to troubleshoot the system, make sure the battery is fully charged, there are no visible signs of external damage to the actuator, motor or rails and that the motor is wired properly and all connections are secure.

You can adjust room extension by modifying the position of the adjustment coupler.

During troubleshooting, remember, by changing, altering or adjusting one thing, it may affect something else. Be sure any changes do not create a new problem.

Additional information on the *Lippert Hydro-Sync Slideout System* by calling 866-524-7821 and asking for technical assistance.

TROUBLESHOOTING CHART

The following troubleshooting chart outlines some common problems, their causes and possible corrective actions. When reference is made to a "Power Unit," the term includes the motor and the actuator as a complete unit. All Power Units are shipped from the factory with a serial number and date code, which should be given to the service technician when asking for assistance.

ROOM DOESN'T MOVE WHEN SWITCH IS PRESSED	
PROBABLE CAUSE	CORRECTIVE ACTION
Restrictions both inside and outside of unit	Check for and clear restriction
Low battery voltage, blown fuse, defective wiring	Check battery. Charge battery or add auxiliary power source. Check battery terminals, and all other wiring. Look for loose or corroded connections
Power Unit not functioning	See "Power Unit Troubleshooting" page 13
POWER UNIT RUNS, ROOM DOES NOT MOVE	
Restrictions both inside and outside of unit	Check for and clear restriction
POWER UNIT RUNS, ROOM MOVES SLOWLY	
Low battery, poor ground, extremely low outdoor temperature	Charge battery, and check ground wire
Leaking cylinder	See "Checking for Bad Cylinder" page 14
ROOM DRIFTS IN BOTH IN & OUT POSITIONS	
Check for leaks in the hydraulic system	Tighten fittings
Air in system	After checking all connections, cycle pump several times in and out
IN THE CLOSED POSITION, ROOM DRIFTS OUT	
Leaking cylinder seal	See "Checking for Bad Cylinder" page 14
Fluid bypassing cylinder piston	See "Checking for Bad Cylinder" page 14
Hose from pump is leaking	Tighten fitting or replace hose
Air in system	After checking all connections, cycle pump several times in and out
Loose mounting bolts	Tighten mounting bolts
IN THE OPEN POSITION, ROOM DRIFTS IN	
Hose from pump is leaking	Tighten fitting or replace hose
Leaking cylinder seal	See "Checking for Bad Cylinder" page 14
Fluid bypassing cylinder piston	See "Checking for Bad Cylinder" page 14

TROUBLESHOOTING – POWER UNIT

Before attempting to troubleshoot the Power Unit, make sure an adequate power source is available. The unit batteries should be fully charged or the unit should be plugged into to A/C service with batteries installed. Do not attempt to troubleshoot the Power Unit without assuring a full 12V DC charge

The following tests require only a DC voltmeter (or DC test light) and a jumper lead.

Step 1 - Attach voltmeter (or test light) leads to the negative and positive switch terminals on back of wall switch (See Fig. 9). Does the meter indicate 12V DC?

If **YES**, see **Step 2**; if **NO** see **Step 3**.

Step 2 - If **YES**, at the motor, check the incoming leads to 12V DC (if necessary, disconnect leads at wire splices). Does meter indicate 12V DC? If **YES**, Power Unit needs to be replaced. The motor is not field serviceable. DO NOT ATTEMPT TO REPAIR. If **NO**, Inspect all wires and connections between the wall switch and the motor. Repair connections as necessary. Recheck as in **Step 1**.

Step 3 - If **NO**, Inspect all connections between battery and switch. Inspect 50A Auto-reset Circuit Breaker (See Fig. 9). Recheck as above in **Step 1**.

TROUBLESHOOTING - ELECTRICAL

Since there are no field serviceable parts in the motor of the Power Unit, electrical troubleshooting and service is limited to replacing only those components as previously outlined.

Thorough inspection of wiring and connections is the only other electrical service that can be performed.

TROUBLESHOOTING – CHECKING FOR BAD CYLINDER

1. Retract (close) the slideout (room) completely.
2. Loosen hose from “E” (extend) port on the manifold of the Power Unit.

WARNING-

Do not attempt to run room out with the “E” port hose loose.

The

system will experience RAPID FLUID LOSS.

3. Plug opening on manifold to prevent drawing air into the system.
4. Energize the Power Unit to retract (close) room.
5. Continue to run the room in and watch for fluid flow from hose/port “E”. Fluid flow greater than a few drops will indicate internal cylinder leaking (bypassing of piston seal). If there is no fluid flow, reconnect hose to “E” port and tighten.

WARNING -

Be sure to reconnect and tighten hose at the “E” port before attempting to extend (open) the room or the system will experience RAPID FLUID LOSS.

Contact qualified technician if there is excessive fluid flow. The cylinder should not be repaired in the field.

Refill the Power Unit Reservoir as recommended on page 12 of this manual.

WIRING DIAGRAM

Fig. 9

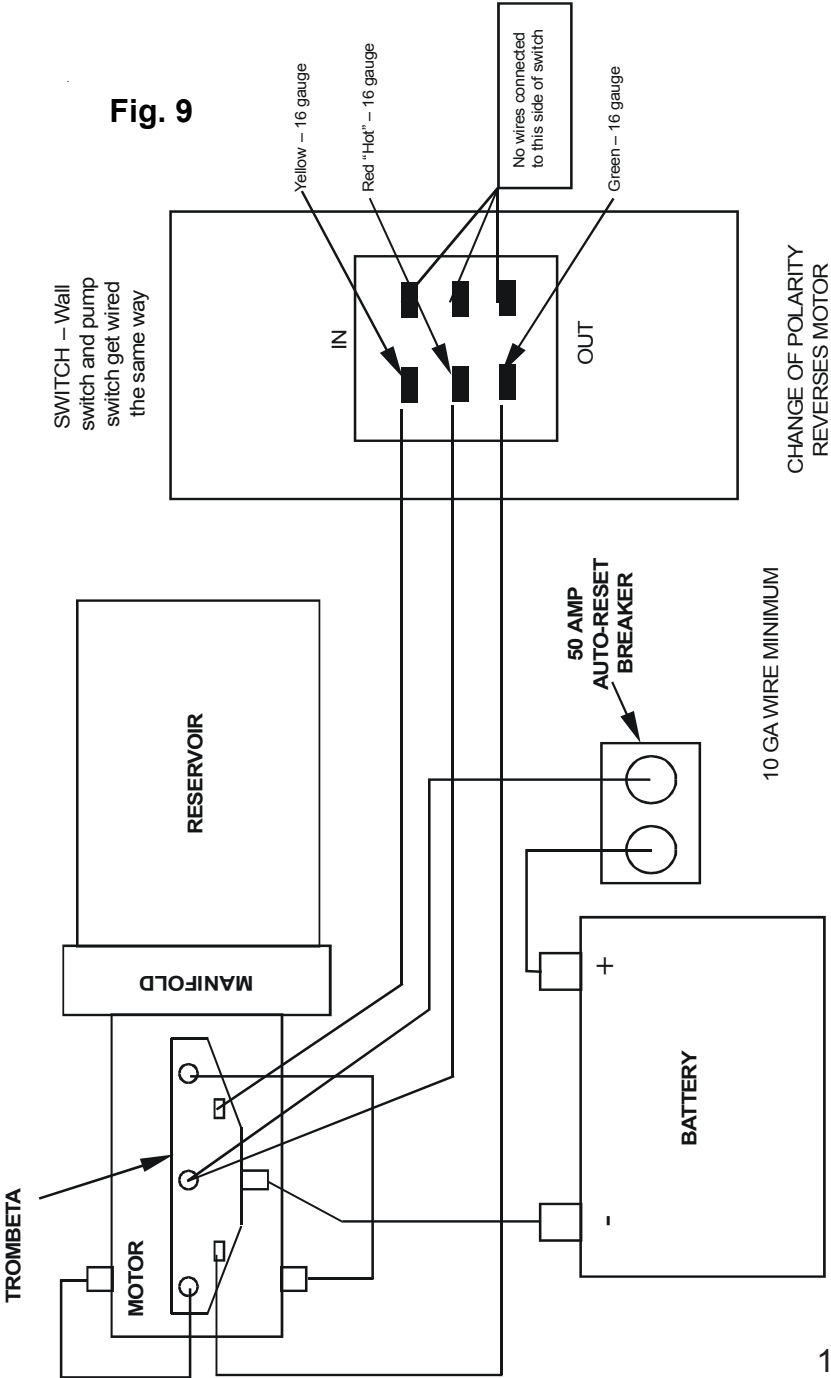

ORDERING PARTS

To assist the customer service when ordering parts, please provide the following information:

1. Your Name
2. Company Name
3. Phone Number
4. Shipping Address
5. Billing Address
6. Purchase Order Number
7. Coach
 - A. Serial # and/or VIN #
 - B. Make
 - C. Model
8. Part Number
9. Description
10. Quantity

Please take your coach to an authorized service center for repairs. Systems that have been modified, adjusted, repaired or augmented by a party other than an authorized service center may void any warranty claim with Lippert Components, Inc.